

Product Details

Magnifying Mirrors Lighted

Lumina

LED Mirror



- LED - Technology
- Acrylic screen design
- Maintenance free - 50.000 h lifespan
- Energy saving
- Brighter focused light
- Twin arm
- 3 x magnification
- Vertical and swing adjustments
- Class I
- 120-240 V



► Hard wire application:

Code	Version	Diameter
020811	chrome	ø 220 mm

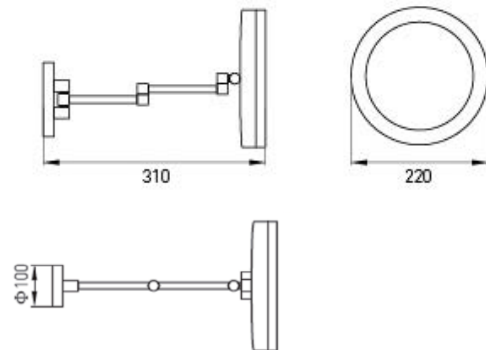

Cleaning Instructions - Magnifying Mirrors:

- Mirror Lens
Wipe down with a light solution of soap suds. Do NOT use sponges or cloths that may damage the surface. Wipe with a damp cloth. Polish with a dry soft cotton cloth.
- Chrome Trim & Arms
Do NOT use any cleaners containing acids, ammonia or abrasives. The use of such products even in a diluted form may damage the finish.

ALISEO GmbH · Leutkirchstraße 63 · 77723 Gengenbach

Tel. +49 (0) 7803-60279-0

Fax +49 (0) 7803-60279-30

E-Mail: info@aliseo.de · Internet: www.aliseo.de

ALISEO GmbH
G E R M A N Y

产品详细信息

带灯化妆镜

Lumina

LED Mirror



- LED 芯片发光技术
- 亚克力透光镜盖设计
- 使用寿命: 30.000 小时持续照明
- 节约能耗
- 带灯圆形双臂化妆镜
- 3倍放大镜面
- 镜面双轴旋转关节
- 一类绝缘
- 120-240V
- 建议安装高度: 离地155-160cm, 具体根据使用者身高做微调
- 建议墙面开孔直径: 1.5cm, 并预留三厢线

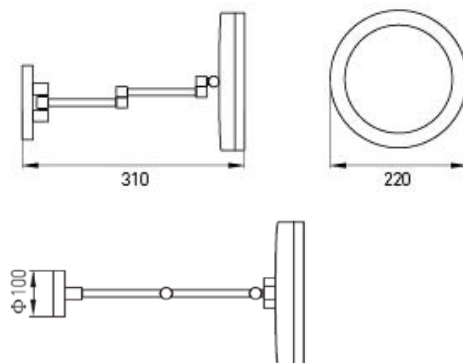

化妆镜-清洁保养指导

镜面

- 用柔软的纯棉布蘸清水或低浓度肥皂水以打圈的方式轻柔擦拭镜面；切勿使用可能损伤镜面的海绵或硬布。

镀铬表面及镜臂

- 用柔软的纯棉布沾低浓度肥皂水擦拭清洁，去除表面沉积的灰尘污垢，再用干净的纯棉布轻柔擦干表面，以保证表面光泽亮丽；切勿使用含有氢、氯、磷、乙酸或醋酸等具有腐蚀性的清洁剂；切勿使用含有漂白剂、磨损性或洗涤性的清洗剂，类似产品会损伤镀铬表面。



➤ 墙装式

型号	表面处理	直径
020811	镀铬	∅ 220 mm

ALISEO GmbH · Leutkirchstraße 63 · 77723 Gengenbach

Tel. +49 (0) 7803-60279-0

Fax +49 (0) 7803-60279-30

E-Mail: info@aliseo.de · Internet: www.aliseo.de

ALISEO GmbH
G E R M A N Y